



## HyperGrip® - Push/Pull Plastic Circular Connectors

- For medical and other high reliability applications
- Customer-keyable (6 positions)
- 5 (HG0), 12 (HG2), 19 (HG3), 33 (HG4), or 80 (HG6) contact positions
- Other contact configurations available upon request
- 1 Amp per contact
- Color coding
- Overmoldable plug design
- Front or rear panel mount receptacle design
- High-end engineering plastic components meet medical sterilizing and cleaning requirements
- Crimp and solder cup contact terminations available (printed circuit tails available on panel mount receptacle)
- Sealing option: IP67 (temporary immersion) when mated
- Meets fingerproofing requirements per IEC60601-1

US Patent Numbers: 7,326,091 B2; 7,661,995 B2; D 596,127 S

	HG0	HG2	HG3	HG4
<b>A</b>	Ø0.807 [20.50]	Ø1.014 [25.76]	Ø1.172 [29.77]	Ø1.250 [31.77]
<b>B</b>	0.728 [18.50]	1.220 [30.88]	1.220 [30.88]	1.220 [30.88]
<b>C</b>	Ø0.630 [16.00]	Ø0.866 [22.00]	Ø1.007 [25.59]	Ø1.090 [27.80]
<b>D</b>	0.285 [7.25]	0.272 [6.91]	0.272 [6.91]	0.272 [6.91]
<b>E</b>	1.040 [26.38]	1.808 [45.92]	2.170 [55.07]	2.170 [55.07]
<b>F</b>	0.343 [8.71]	0.427 [10.84]	0.354 [9.00]	0.354 [9.00]
<b>G</b>	Ø0.370 [9.40]	Ø0.502 [12.75]	Ø0.650 [16.50]	Ø0.710 [18.15]
<b>H</b>	Ø0.486 [12.34]	Ø0.656 [16.66]	Ø0.800 [20.36]	Ø0.880 [22.47]
<b>J</b>	1.415 [35.94]	2.390 [60.65]	2.730 [69.33]	1.869 [47.48]
<b>K</b>	0.118 [3.00]	0.118 [3.00]	0.118 [3.00]	0.118 [3.00]
<b>L</b>	0.689 [17.50]	0.823 [20.90]	0.980 [24.90]	1.060 [26.90]
<b>M</b>	-	Ø0.433 [11.00]	Ø0.535 [13.60]	Ø0.610 [15.50]
<b>N</b>	-	Ø0.197 [5.00]	Ø0.378 [9.60]	Ø0.378 [9.60]
<b>P</b>	-	1.704 [43.27]	1.961 [49.82]	2.124 [53.95]

### General Specifications - HyperGrip

Number of Contacts	5	12	19	33	85
Contact Diameter	0.012 [0.30]		0.016 [0.40]		
Current Rating (Amps)	1.0				
Contact Resistance (milliohms)	< 8.0				
Contact Extraction Force Each (oz.)	0.50 to 1.60				
Termination Styles Available	Crimp (Pin and Socket) Solder Cup (Pin and Socket) optional Printed Circuit Terminal (Socket) optional				
Contact Life Cycles	up to 100,000				
Plug Cycle Life	up to 20,000				
Breakdown Voltage Between Contacts (max.)	1000V				
Dielectric Withstanding Voltage	750V				
Shielded Connectors	Shielding Effectiveness Attenuation				
	up to 3 GHz 50 dB maximum at 3 GHz				
Contact Material and Plating	<b>Sockets:</b> Beryllium copper wires and brass body components Gold over nickel <b>Pins:</b> Phosphorus Bronze Gold over nickel				
Insulation Resistance	> 5 x 10 <sup>4</sup> megohms at 500 VDC				
Temperature Rating	Polyetherimide, LCP, Silicone -40° C to 125° C up to 185° C processing				
Sterilization	Steam autoclave, Gamma, ETO, Sterrad®				

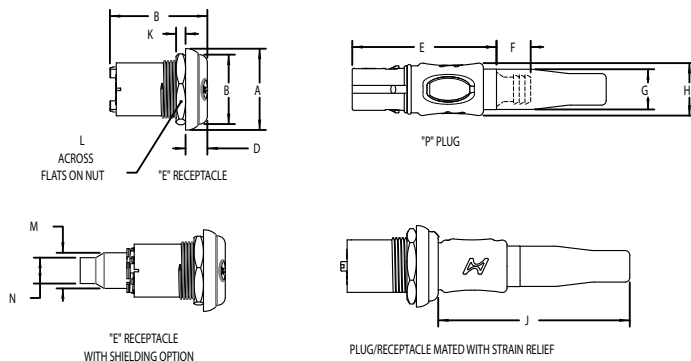

**NOTE:**

1) Recommended tightening torque for panel mount receptacle for HG2, HG3 and HG4 is (0.452 to 0.678 N•m). For HG0 (0.226 to 0.339 N•m).

Sterrad is a trademark of Advanced Sterilization Products (ASP)

Dimensions are in inches [mm]

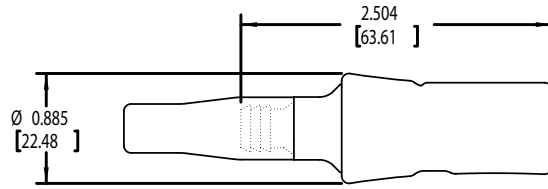

**“C” Cable Receptacle  
HG2 Only**

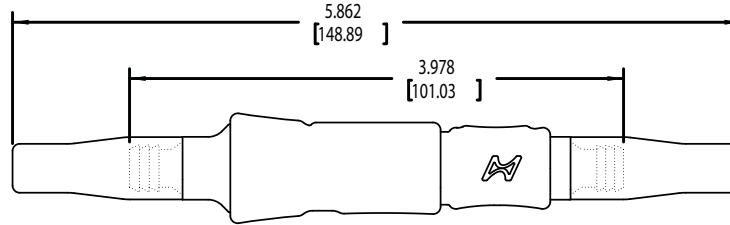

**Plug/Cable Receptacle Mated  
HG2 Only**

**HG6 Only**

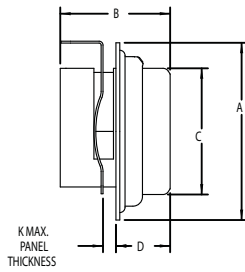

**\*E\* RECEPTACLE  
HG6 ONLY**

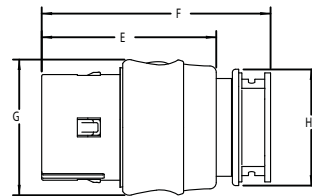

**\*E\* PLUG  
HG6 ONLY**

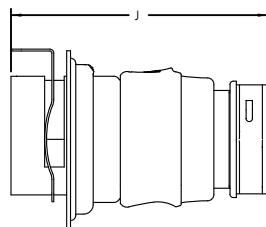

**PLUG/RECEPTACLE MATED PAIR  
HG6 ONLY**

	<b>HG6</b>
<b>A</b>	Ø2.026 [51.45]
<b>B</b>	1.452 [36.87]
<b>C</b>	Ø1.789 [45.45]
<b>D</b>	0.669 [17.00]
<b>E</b>	2.224 [56.50]
<b>F</b>	4.950 [125.72]
<b>G</b>	Ø1.693 [43.00]
<b>H</b>	Ø1.446 [36.73]
<b>J</b>	4.371 [111.02]
<b>K</b>	0.197 [5.00]

## Receptacle Keying

**Keying Position A**  
(Receptacle Wiring End)

**HG2**  
shown

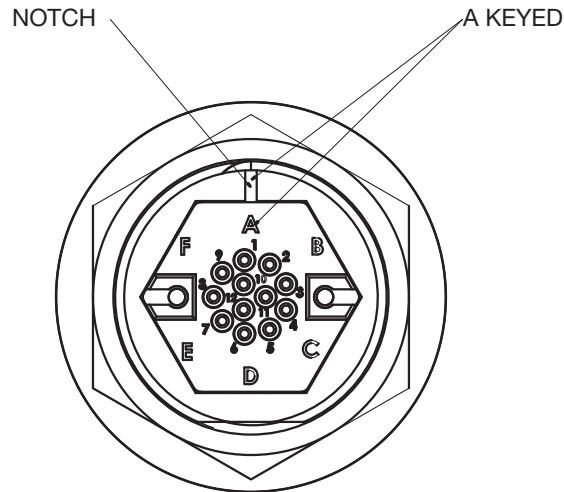

**NOTE:**  
6 different keying positions possible - A through F.

Dimensions are in inches [mm]

## Optional Mounting Section

### HG Panel Receptacle (HG2, 3, 4 and 6) Printed Circuit Board Cutouts

#### 12 Position (HG2)

“A” Key (D Termination)

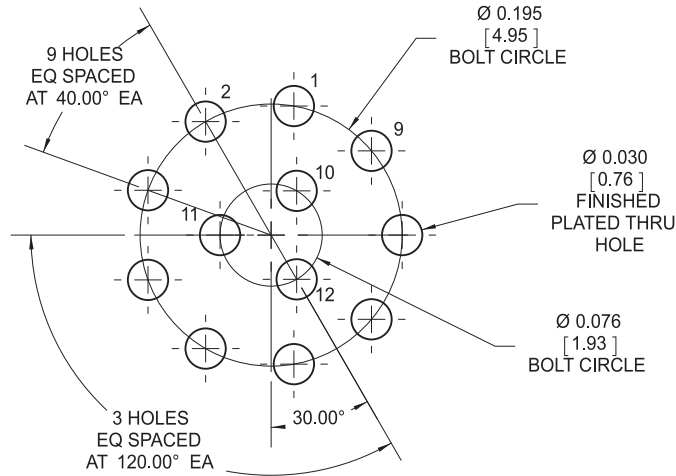

#### 19 Position (HG3)

“A” Key (D Termination)

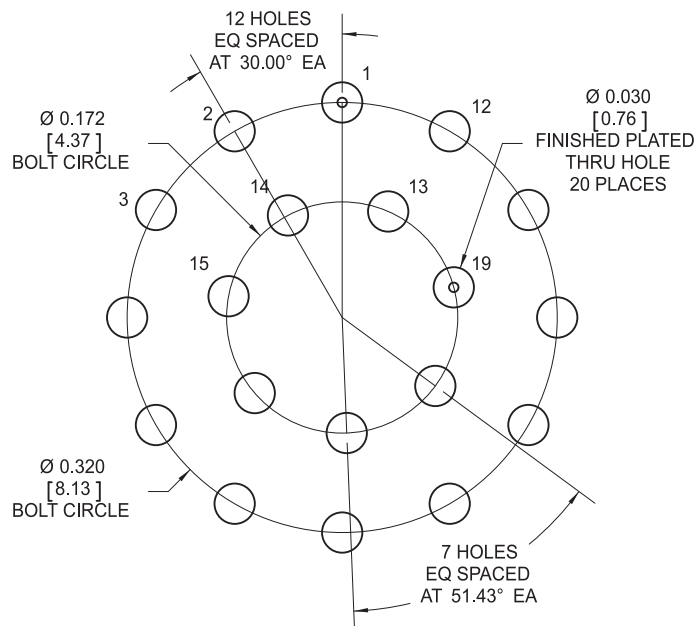

Dimensions are in inches [mm]

## Optional Mounting Section

### 33 Position (HG4)

"A" Key (D Termination)

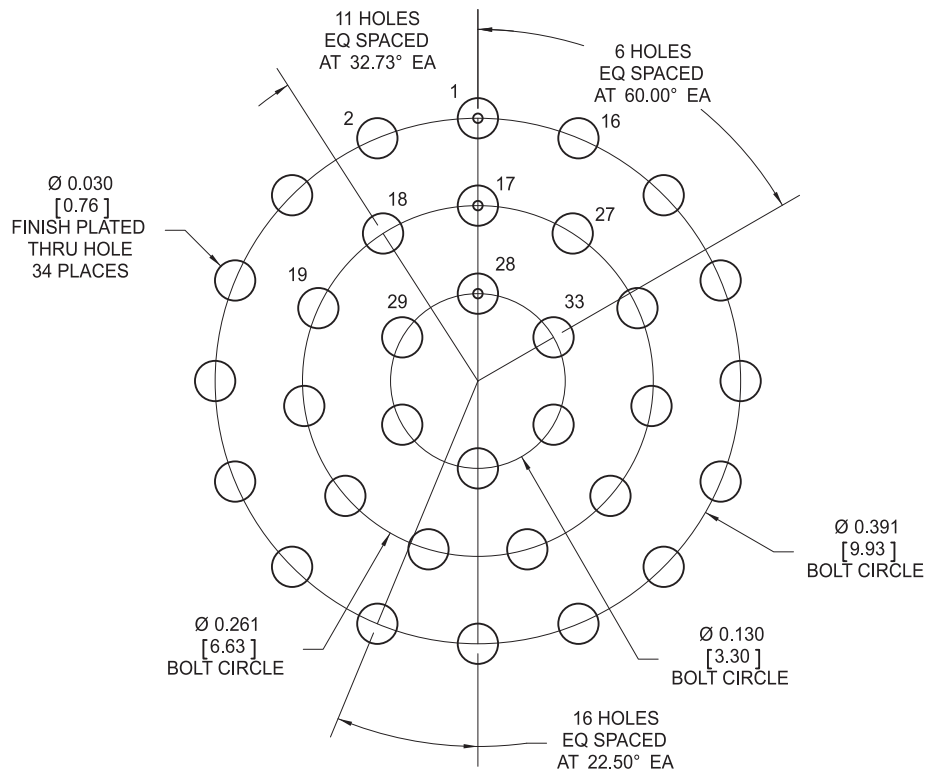

Dimensions are in inches [mm]

**Optional Mounting Section**

**80 Position (HG6)**

“A” Key (D Termination)

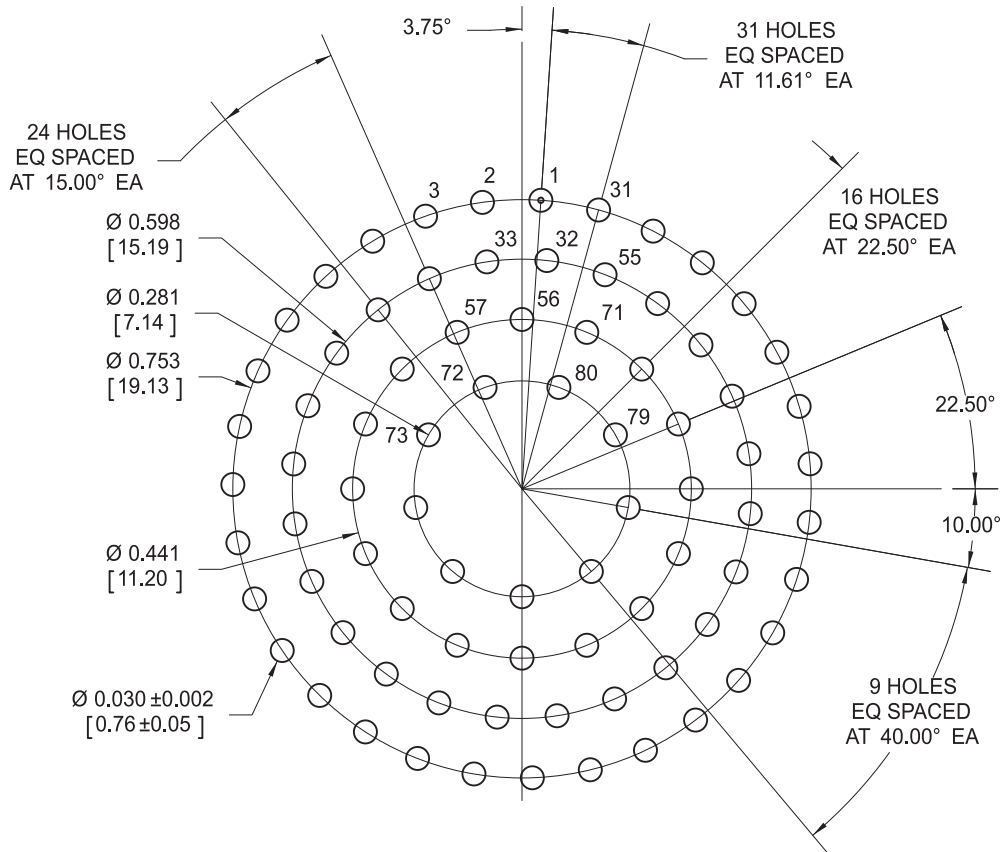

Dimensions are in inches [mm]

## Panel Cutouts

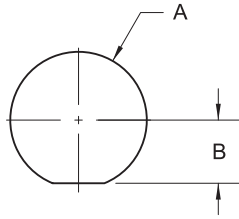

Dimension		
	A	B
	+0.002 -0.001 [+0.050 -0.030]	±0.001 [±0.030]
HG0	Ø0.555 [14.10]	0.240 [6.10]
HG2	Ø0.711 [18.06]	0.329 [8.36]
HG3	Ø0.870 [22.10]	0.393 [9.98]
HG4	Ø0.949 [24.10]	0.430 [10.92]
HG6	Ø1.583 [40.21]	0.714 [18.14]

### Front Mounting Installation

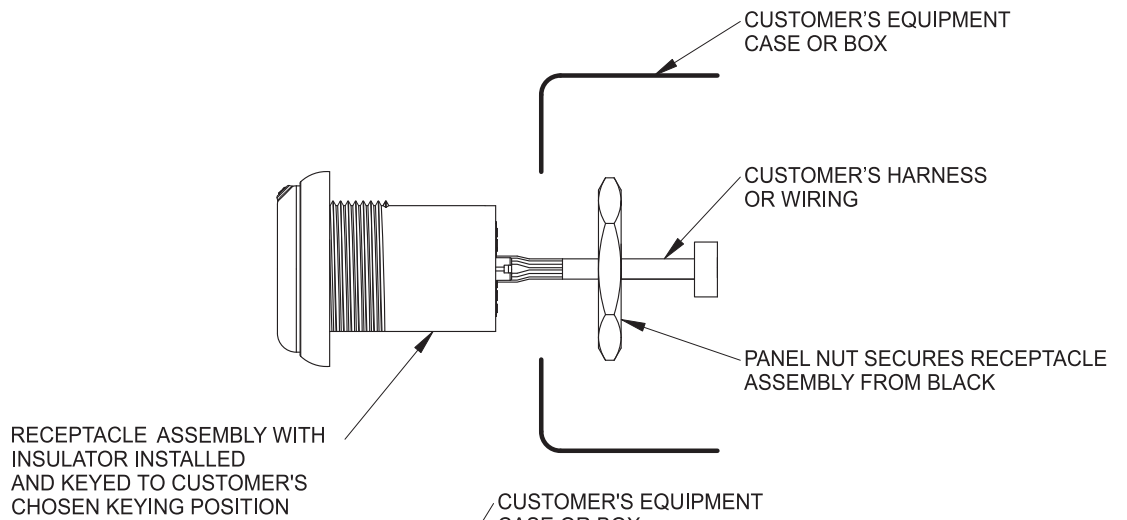

### Rear Mounting Installation

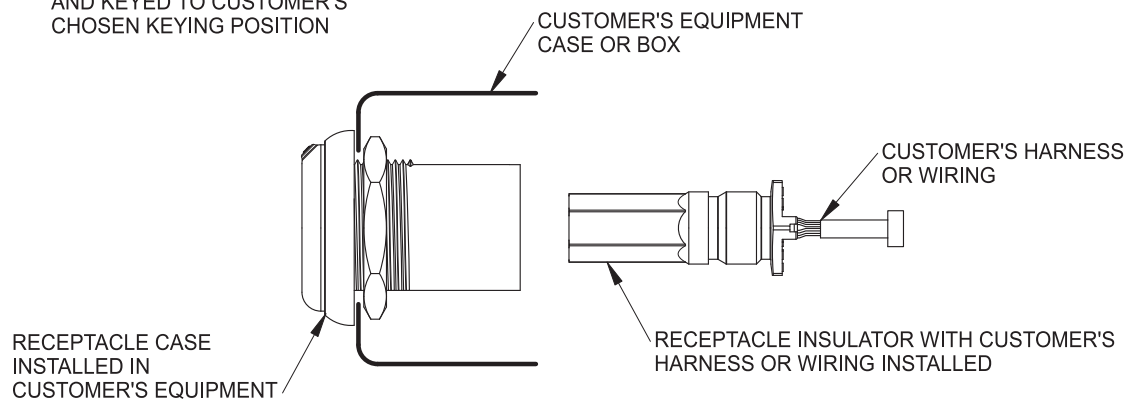

Dimensions are in inches [mm]

## Ordering Information

HG
2
P
4
3
G
G
12
04
M
R
H

**HyperGrip Plastic Circular**

**Size** Size: (0), (2), (3), (4), (6)

**Type**  
 P = Plug  
 E = Receptacle/panel  
 C = Receptacle/cable  
 (C available on HG2 only)

**Connector Options**  
 1 = Sealed  
 2 = Shielded (unsealed)

**Strain Relief Size Options**  
 0 = No strain relief  
 1 = 2.80 - 3.10mm cable dia. range (HG0 only)  
 3 = 3.00 - 4.50mm cable dia. range (HG2 only - optional)  
 4 = 4.50 - 6.50mm cable dia. range (HG2 only - standard)  
 5 = 7.00 - 9.00mm cable dia. range (HG3 only)  
 6 = 9.00 - 11.00mm cable dia. range (HG4 only)

**Outer Shell Color**  
 G = LT gray

**Color Coding**  
 G = LT Gray (standard)  
 D = Blue  
 M\* = Brown  
 R = Red  
 V = Green  
 B\* = Black  
 Y = Yellow  
 W\* = White  
 N<sup>1</sup> = No color code

**Plating**  
 H = Pins: 50µin gold on contact surfaces, gold flash on terminations  
 AH = Sockets: 50µin gold on contact surfaces, gold flash on terminations (Omit for no contacts)

**Termination**  
 S = Solder cup (optional)  
 R = Crimp (standard)  
 D = Straight dip printed circuit (optional)  
 Panel receptacle only (Omit for no contacts)

**Contact Gender**  
 F = Female sockets (standard receptacle)  
 M = Male pins (standard plug)  
 N = No contacts

Size	HG0	HG2	HG3	HG4	HG6
<b>Contact Diameter</b>	0.30mm	0.40mm	0.40mm	0.40mm	0.40mm
<b>Positions</b>	5	12	19	33	80

\* Color is special order only.

**NOTES**  
 HG0 panel mount receptacle is available with 6 inch pigtailed and can be ordered under part number HG0E10GG-0001

Available Contacts	Wire Gauge (AWG)
<b>Termination Styles Available</b> Crimp (Pin and Socket) Solder Cup (Pin and Socket) optional Printed Circuit Terminal (Socket) optional	26 to 28 AWG up to 26 AWG N/A

Accessories	Part Numbers
Crimp Tool	AFM8 or M22520/2-01
Positioner	K1775 (HG0)
Insertion Tool	T2030 (HG2, 3, 4, 6)
Receptacle Insulator Extraction Tool	T2080 T2057 (HG2) T2085-20 (HG3) T2085-34 (HG4) T2085-85 (HG6)

**NOTE:**  
 1) If N applies: Plug and cable receptacle - specify no strain relief.  
 Panel receptacle - specify unsealed (no panel color code).

Dimensions are in inches [mm]